

# SMD Aluminum Electrolytic Capacitor – JCD

## FEATURES

- Endurance : 105°C 2000H.
- Low Impedance .
- Designed for reflow soldering.
- Designed for surface mounting on high-density PCB.



Fig 1

Fig 2

Fig 3

## SPECIFICATIONS

Operating Temperature  
Voltage Range  
Capacitance Range  
Capacitance Tolerance  
Leakage Current  
Dissipation Factor (Tan δ)

-55°C ~ +105°C  
6.3V ~ 100V.DC  
1 ~ 4700μF  
±20% at 120Hz, 20°C  
I ≤ 0.01 CV or 3 μA whichever is greater (after 2 minutes)  
Measurement Frequency: 120Hz, Temperature: 20°C

Note: Fig 1 & 2: Diameter 4 ~ 10mm

Fig 3 : Diameter: ≥12.5mm

Rated Voltage (V)	6.3	10	16	25	35	50	63	80	100
Tan δ	Φ4~Φ10	0.28	0.22	0.20	0.16	0.14	0.12	0.12	0.12
(Max.)	Φ12.5~Φ16	0.34	0.28	0.22	0.20	0.16	0.14	0.14	0.14

Stability At Low Temp.

Measurement Frequency: 120Hz

Rated Voltage (V)		6.3	10	16	25	35	50	63	80	100
Impedance Ratio ZT/Z20 (Max.)	Φ4~Φ10	Z(-25°C)/ Z(20°C)	4	4	3	3	2	2	2	2
		Z(-55°C)/ Z(20°C)	10	7	5	5	4	4	3	4
	Φ12.5~Φ16	Z(-25°C)/ Z(20°C)	4	3	3	3	2	2	2	2
		Z(-55°C)/ Z(20°C)	10	7	5	5	4	4	3	4

Load Life

After applying rated working voltage for 2000 hours at +105°C ± 2°C, and then being stabilized at +20°C, capacitors shall meet the following limits.

Capacitance Change	Within ± 25% of initial value.
Dissipation Factor	Less than 250% of the initial value
Leakage Current	Within the initial limit

Shelf Life

After storage for 1000 h at +105°C ± 2°C with no voltage applied and then being stabilized at +20°C, capacitors shall meet the limits specified in endurance.

Resistance to Soldering Heat

After reflow soldering and then being stabilized at +20°C, capacitors shall meet the following limits.

Capacitance Change	Within ± 10% of initial value
Dissipation Factor	Within the initial limit
Leakage Current	Within the initial limit

## DRAWING (Unit: mm)

(Φ 4 ~ Φ 8x6.2)

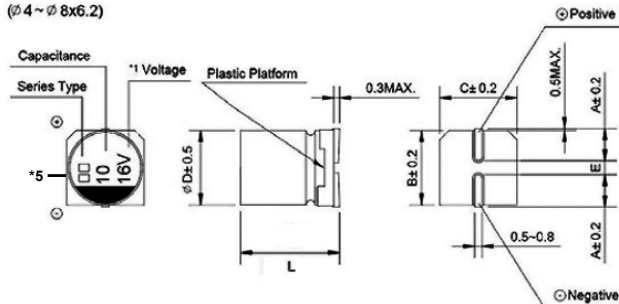

(Φ 8x10.5 ~ Φ 16)

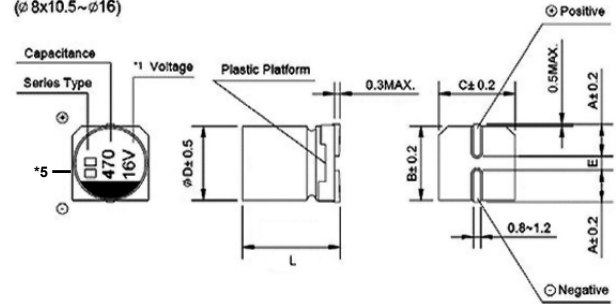

\*1 Voltage mark for 6.3V is [6V] or [6.3V] \*5 Surface Marking Types: jD, jD, LZ

Please visit our website to get more update data, those data & specification are subject to change without notice.

## SMD Aluminum Electrolytic Capacitor – JCD

### DIMENSIONS (Unit: mm)

∅DxL	4x5.4	5x5.4	6.3x5.4 (6.3x7.7)	8x6.5 (8x 10.5)	10x7.7 (10x10.5) (10x 13.5)	12.5x13.5
A	2.0	2.2	2.6	3.0	3.3	4.9
B	4.3	5.3	6.6	8.4	10.4	13.0
C	4.3	5.3	6.6	8.4	10.4	13.0
E±0.2	1.0	1.4	1.9	2.2 / 3.1	4.7	4.7
L	5.4±0.6	5.4±0.6	5.4/7.7±0.6	10.5±0.6	10.5/13.5±1.0	13.5/16±1.0

### DIMENSIONS&MAXIMUM PERMISSIBLE RIPPLE CURRENT&IMPEDANCE

WV/V Cap/μF		6.3			10			16		
		0J			1A			1C		
10	100							4x5.4	3.00	60
22	220	4x5.4	3.00	60	4x5.4	3.00	60	4x5.4 (5x5.4)	3.00 (1.80)	60 (95)
33	330	4x5.4	3.00	60	4x5.4	3.00	60	5x5.4 (6.3x5.4)	1.80 (1.00)	95 (140)
47	470	5x5.4	1.80	95	5x5.4 (6.3x5.4)	1.80 (1.00)	95 (140)	5x5.4 (6.3x5.4)	1.80 (1.00)	95 (140)
68	680							8x6.5	0.60	230
100	101	5x5.4 (6.3x5.4)	1.80 (1.00)	100 (140)	5x5.4 (6.3x5.4)	1.80 (1.00)	100 (140)	6.3x5.4 (6.3x7.7) (8x6.5)	1.00 (0.60) (0.60)	140 (230) (230)
150	151				6.3x5.4	1.00	140	6.3x7.7 (8x10.5)	0.60 (0.45)	230 (450)
220	221	6.3x5.4 (6.3x7.7)	1.00 (0.60)	140 (230)	6.3x5.4 (6.3x7.7) (8x10.5)	1.00 (0.60) (0.45)	140 (230) (450)	6.3x7.7 (8x6.5) (8x10.5)	0.60 (0.60) (0.45)	230 (230) (450)
330	331	6.3x7.7 (8x10.5)	0.60 (0.45)	230 (450)	8x10.5	0.45	450	8x10.5 (10x7.7)	0.45 (0.45)	450 (450)
470	471	6.3x7.7 (8x10.5)	0.60 (0.45)	230 (450)	8x10.5	0.45	450	8x10.5 (10x10.5)	0.45 (0.25)	450 (670)
680	681							10x10.5	0.25	670
820	821	8x10.5 (10x10.5)	0.40 (0.25)	450 (670)						
1000	102	10x10.5	0.25	670	10x10.5	0.25	670	10x10.5 (10x13.5)	0.25 (0.15)	670 (750)
1500	152	10x10.5	0.25	670				12.5x13.5	0.12	820
2200	222	12.5x13.5	0.12	820	12.5x13.5	0.12	820	Case Size ∅DxL(mm)	Impedance (Ω) at 20°C 100kHz	Ripple Current (mA rms) at 105°C 100kHz

Please visit our website to get more update data, those data & specification are subject to change without notice

## SMD Aluminum Electrolytic Capacitor – JCD

### DIMENSIONS&MAXIMUM PERMISSIBLE RIPPLE CURRENT&IMPEDANCE

WV/V Cap/μF		25			35			50		
		1E			1V			1H		
1	010							4x5.4	5.00	30
2.2	2R2							4x5.4	5.00	30
3.3	3R3							4x5.4	5.00	30
4.7	4R7	4x5.4	3.00	60	4x5.4	3.00	60	4x5.4 (5x5.4)	5.00 (3.00)	30 (50)
10	100	4x5.4 (5x5.4)	3.00 (1.80)	60 (95)	4x5.4 (5x5.4)	3.00 (1.80)	60 (95)	5x5.4 (6.3x5.4)	3.00 (2.00)	50 (70)
22	220	5x5.4 (6.3x5.4)	1.80 (1.00)	95 (140)	5x5.4 (6.3x5.4)	1.80 (1.00)	95 (140)	6.3x5.4 (6.3x7.7) (8x6.5)	2.00 (1.00) (1.00)	70 (120) (120)
33	330	5x5.4 (6.3x5.4)	1.80 (1.00)	95 (140)	6.3x5.4 (8x6.5)	1.00 (0.60)	140 (230)	6.3x7.7 (8x10.5)	1.00 (0.80)	120 (280)
47	470	6.3x5.4	1.00	140	6.3x5.4 (6.3x7.7) (8x6.5) (8x10.5)	1.00 (0.60) (0.60) (0.45)	140 (230) (230) (450)	6.3x7.7 (8x6.5) (8x10.5)	1.00 (1.00) (0.80)	120 (120) (300)
100	101	6.3x7.7 (8x10.5)	0.60 (0.45)	230 (450)	6.3x7.7 (8x6.5) (8x10.5)	0.60 (0.60) (0.45)	230 (230) (450)	8x10.5 (10x7.7) (10x10.5)	0.80 (0.80) (0.45)	300 (300) (450)
150	151	8x10.5	0.45	450	8x10.5 (10x7.7)	0.45 (0.45)	450 (450)	10x10.5	0.45	450
220	221	8x10.5 (10x7.7) (10x10.5)	0.45 (0.45) (0.25)	450 (450) (670)	8x10.5 (10x10.5)	0.40 (0.25)	450 (670)	10x10.5 (10x13.5)	0.45 (0.35)	500 (550)
330	331	8x10.5 (10x10.5)	0.40 (0.25)	450 (670)	10x10.5	0.25	670	12.5x13.5	0.25	650
470	471	10x10.5	0.25	670	10x13.5	0.15	750	Case Size ØD×L(mm)	Impedance (Ω) at 20°C 100kHz	Ripple Current (mA rms) at 105°C 100kHz
680	681	10x13.5	0.15	750	12.5x13.5	0.12	820			
1000	102	12.5x13.5	0.11	820						

Please visit our website to get more update data, those data & specification are subject to change without notice.

## SMD Aluminum Electrolytic Capacitor – JCD

### DIMENSIONS&MAXIMUM PERMISSIBLE RIPPLE CURRENT&IMPEDANCE

WV/V Cap/μF		63			80			100		
		1J			1K			2A		
4.7	4R7	5×5.4	5.00	50				5×5.4 (6.3×5.4)	5.00 (5.00)	25 (40)
10	100	6.3×5.4	3.00	80	6.3×7.7	3.00	60	6.3×7.7 (8×6.5)	3.00 (3.00)	60 (60)
22	220	6.3×7.7	2.50	100	8×10.5	2.00	130	8×10.5 (10×10.5)	2.00 (1.50)	130 (180)
33	330	8×10.5	2.00	250	10×10.5	1.50	180	10×10.5 (10×13.5)	1.50 (1.20)	180 (210)
47	470	8×10.5	2.00	250	8×10.5	2.00	130	10×10.5	1.50	180
		(10×7.7) (10×10.5)	(2.00) (1.50)	(250) (300)	(10×10.5) (10×13.5)	(1.50) (1.20)	(180) (240)	(10×13.5) (12.5×13.5)	(1.20) (0.85)	(240) (500)
100	101	10×10.5 (10×13.5) (12.5×13.5)	1.50 (1.00) (0.85)	300 (400) (500)	10×10.5 (10×13.5) (12.5×13.5)	1.50 (1.20) (0.85)	180 (240) (500)	12.5×13.5	0.85	500
150	151				12.5×13.5	0.85	500	Case Size ØD×L(mm)	Impedance (Ω) at 20°C 100kHz	Ripple Current (mA rms) at 105°C 100kHz
220	221	12.5×13.5	0.65	550						

### FREQUENCY COEFFICIENT OF ALLOWABLE RIPPLE CURRENT

Frequency		50Hz	120Hz	1KHz	10kHz≤
Coefficient	Full Capacitance	0.60	0.70	0.85	1.00

Please visit our website to get more update data, those data & specification are subject to change without notice.