

# Dipped Tantalum Capacitor – JTA

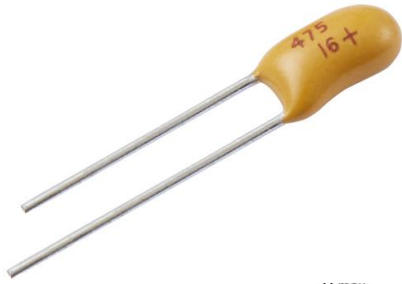

## FEATURES

- Epoxy-coated, Radial-lead, Polarized.
- Small in size, Long life-span, High reliability.
- Stable in electrical & storage performances.
- Applying in TV sets, Telephones, Camcorders, Instruments and Meters, such Electrical Equipment with High-reliable SMT DC & Impulse high-density assembled printed Circuit.

## SPECIFICATIONS

Technical Data

All technical data relate to an ambient temperature of +25°C

Capacitance Range

0.47μF ~ 680μF

Capacitance Tolerance

±20%, ±10%,  
±5% (for special order)

Temperature Range

-55°C to +125°C

Rated Voltage DC (V<sub>R</sub>)

≤+85°C

Category Voltage (V<sub>C</sub>)

≤+125°C

Surge Voltage (V<sub>S</sub>)

≤+85°C

Surge Voltage (V<sub>S</sub>)

≤+125°C

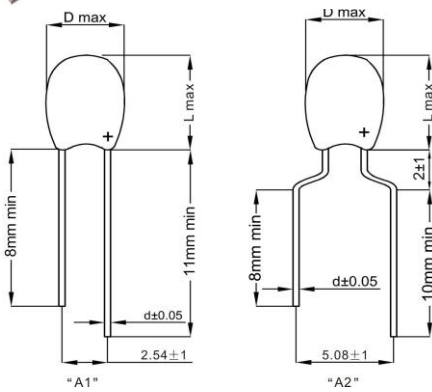

4	6.3	10	16	20	25	35	40	50
2.5	4	6.3	10	13	16	20	25	32
5	8	13	20	26	32	46	52	65
3	5	8	12	16	19	28	31	39

## TEMPERATURE STABILITY

Capacitance Range (μF)	Capacitance Change ΔC/C (%)			Dissipation Factor (%)				DC Leakage	
	-55°C	+85°C	+125°C	-55°C	+25°C	+85°C	+125°C	+85°C	+125°C
0.47~1.0	±10	±10	±15	6	4	6	6	8 I <sub>0</sub> <sup>(1)</sup>	10 I <sub>0</sub>
1.5~6.8				8	6	8	8		
10~68				10	8	10	10		
100~330				12	10	12	12		
470~680				14	12	14	14		
>680				16	14	16	16		

(1) I<sub>0</sub> refer to initial value of DC leakage current

## Capacitance and Rated Voltage Range

Rate Voltage U <sub>R</sub> (V)			4	6.3	10	16	20	25	35	40	50
Category Voltage U <sub>C</sub> (V)			2.5	4	6.3	10	13	16	20	25	32
Dimensions (mm)			Rated Capacitance (μF)								
DxL	d	P									
5.0x9.0 (A case)	0.5	2.54 / 5.08	3.3	1.5	1	0.68	0.33	0.33	0.1	0.1	0.1
			4.7	2.2	1.5	1	0.47	0.47	0.15	0.15	0.15
			6.8	3.3	2.2	1.5	0.68	0.68	0.22	0.22	0.22
			10	4.7	3.3	2.2	1	1	0.33	0.33	0.33
			15	6.8	6.8	3.3	1.5	1.5	0.47	0.47	0.47
			22	10	10	4.7	2.2	2.2	0.68	0.68	--
6.0x9.5 (B case)	0.5	2.54 / 5.08	33	15	15	6.8	3.3	3.3	1	--	--
			--	22	--	10	--	--	1.5	--	--
			47	33	22	15	4.7	4.7	2.2	1	0.68
6.5x10.0 (C case)	0.5	2.54 / 5.08	68	47	33	22	6.8	6.8	3.3	1.5	1
			--	--	--	--	10	10	4.7	2.2	1.5
			100	68	47	33	15	15	6.8	3.3	2.2
6.5x11.5 (D case)	0.5	2.54 / 5.08	150	100	68	47	22	22	10	4.7	3.3
			--	--	100	--	--	--	--	--	--
			220	150	150	68	33	33	15	6.8	4.7
7.5x13 (E case)	0.5	2.54 / 5.08	330	220	--	100	47	47	22	10	6.8
			470	330	220	150	68	68	33	15	10
8.5x13 (F case)	0.5	2.54 / 5.08	--	680	470	330	220	100	100	47	22

P.S:

1) Please do not use multimeter through the measuring procedures.

2) Capacitance and DF measured at: 100Hz U<sub>R</sub> ≈ 2.2<sup>o</sup>-1.0V, U<sub>C</sub> ≈ 1.0<sup>o</sup>-0.5V, Frequency=100Hz. Test only applied in series equivalent circuit.

3) Voltage derating is applied at +125°C. (The DCL parameter should be read after 5 minutes when it connected to the circuit).

Please visit our website to get more update data, those data & specification are subject to change without notice.



# Dipped Tantalum Capacitor – JTA

Operating Voltage		
	-55°C to 85°C	85°C to 125°C
% Change in Working DC Voltage with Temperature	VR	67% of VR
Recommended Max Application Voltage	50% of VR	33% of VR

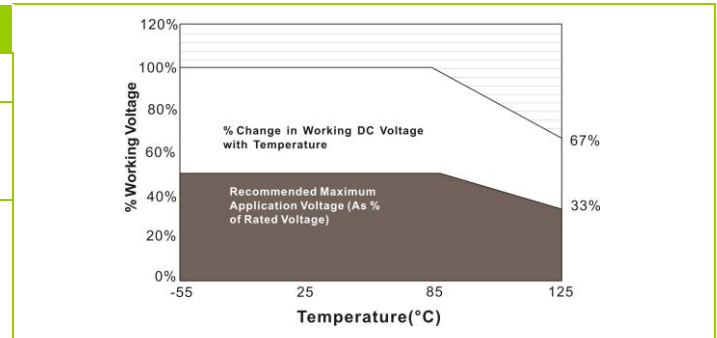

### Reverse Voltage

Since tantalum capacitor has polarity, do not apply a reverse voltage to it. Do not apply capacitor to a circuit which only has alternating current.

- If there is no alternation, applying a low reverse voltage which is listed below to capacitor in a short time is approved.
- In principle, testing a circuit with tantalum capacitor or capacitor itself by using a resistor gear of millimeters in ignorance of polarity is forbidden.
- During measurement and application, if the tantalum capacitor is subjected to an undesirable reverse voltage due to carelessness, please dispose it, even if its electrical characteristics are still qualified.

Temp.	Max. Reverse voltage in a short time
25°C	10% UR (rated voltage), working voltage to maximum of 1.0V.
85°C	3% UR (rated voltage), working voltage to maximum of 0.5V.
125°C	1% UR (rated voltage), working voltage to maximum of 0.1V.

### Ripple Voltage

Please use the capacitor within permissible ripple voltage.

- The sum of DC bias voltage and the maximum AC branch voltage should not exceed rated voltage during operation.
- The sum of negative peak AC value and DC bias voltage should not exceed the specified reverse voltage.
- Ripple current applied to capacitor will generate active power loss, which will raise the rate of the failure caused by heat due to self-heat generation of capacitor. Therefore, ripple current and permissible power loss must be in control.

### Soldering Process

jb tantalum capacitors are compatible with wave (single or dual), convection, IR, or vapor phase reflow techniques. Preheating of these components is recommended to avoid extreme thermal stress. jb's recommended profile conditions for convection and IR reflow reflect the profile conditions of the IPC/J-STD-020D standard for moisture sensitivity testing. The devices can safely withstand a maximum of three reflow passes at these conditions.

Hand soldering should be performed with care due to the difficulty in process control. If performed, care should be taken to avoid contact of the soldering iron to the molded case. The iron should be used to heat the solder pad, applying solder between the pad and the termination, until reflow occurs. Once reflow occurs, the iron should be removed immediately. "Wiping" the edges of a chip and heating the top surface is not recommended.

During typical reflow operations, a slight darkening of the gold-colored epoxy may be observed. This slight darkening is normal and not harmful to the product. Marking permanency is not affected by this change.

### Soldering Process

Profile Feature	Pb-free Assembly	SnPb Assembly
Pre-heating	50~165°C	50~165°C
	90~120 sec.	90~120 sec.
Max. Peak Temperature	250~260°C	240~250°C
Time of wave	3~5 sec.	3~5 sec.
	(max. 10 sec.)	(max. 10 sec.)

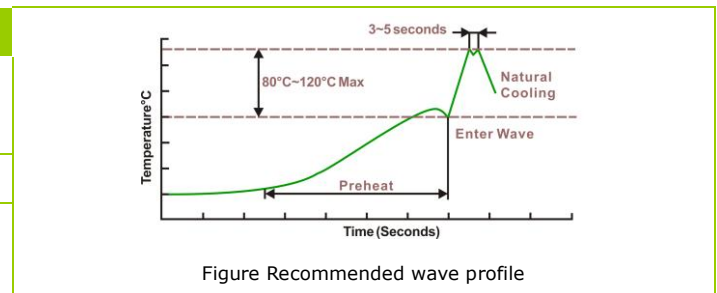

The upper side temperature of the board should not exceed +150°C.

Please visit our website to get more update data, those data & specification are subject to change without notice.

# Dipped Tantalum Capacitor – JTA

## Dimension of Ammo

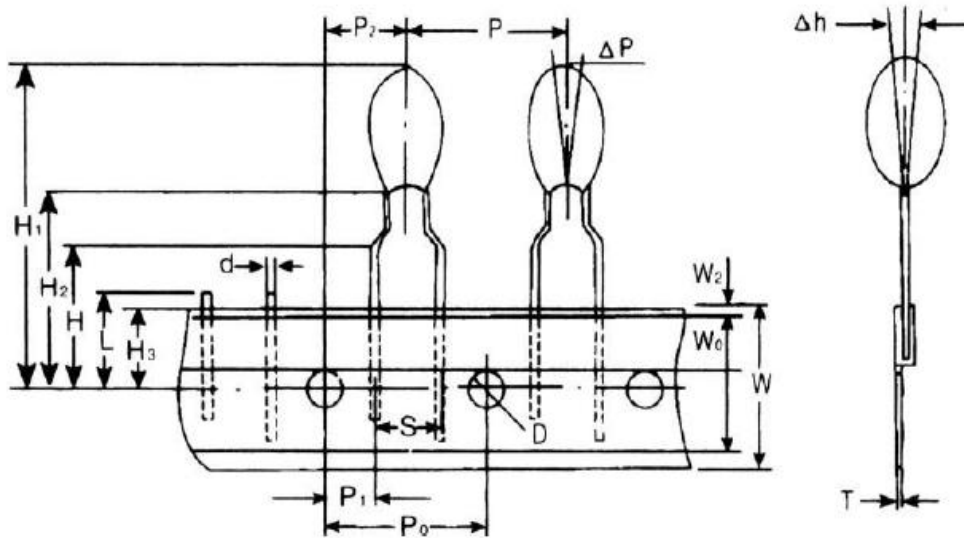

Designation	Symbol	Dimensions(mm)	
Pitch of component	P	12.7±1.0	
Feed hole pitch	P0	14±2	
Tape width	W	18 +/--1	
Hold down tape width	W0	10.5±2	
Hole position	H3	9 +/--0.75	
Hold down tape position	W2	3.0max	
Overall component height	H1	32.5max	
Component alignment	△P	±1.3max	
Feed hole diameter	D	4.0±0.2	
Tape thickness	T	0.5±0.2	
Component alignment	△h	±2.0max	
Length of snipped leads	L	11max	
Lead clinch height	H	17±2	
Lead wire spacing	S	2.54±1	5.08±1
Feed hole center to wire center	P1	5.10±0.5	3.85±0.7
Hole center to component center	P2	6.35±0.4	
Component height	H2	18 +/--2	
Lead diameter	d	0.5±0.05	

Please visit our website to get more update data, those data & specification are subject to change without notice.